

Sandia

Great Southwest Council

District

Cub Scout Roundtable

Games, Songs, Ceremonies,
Crafts, and much more -
For All Ranks

Webelos
Citizen
Showman

Down on the Farm

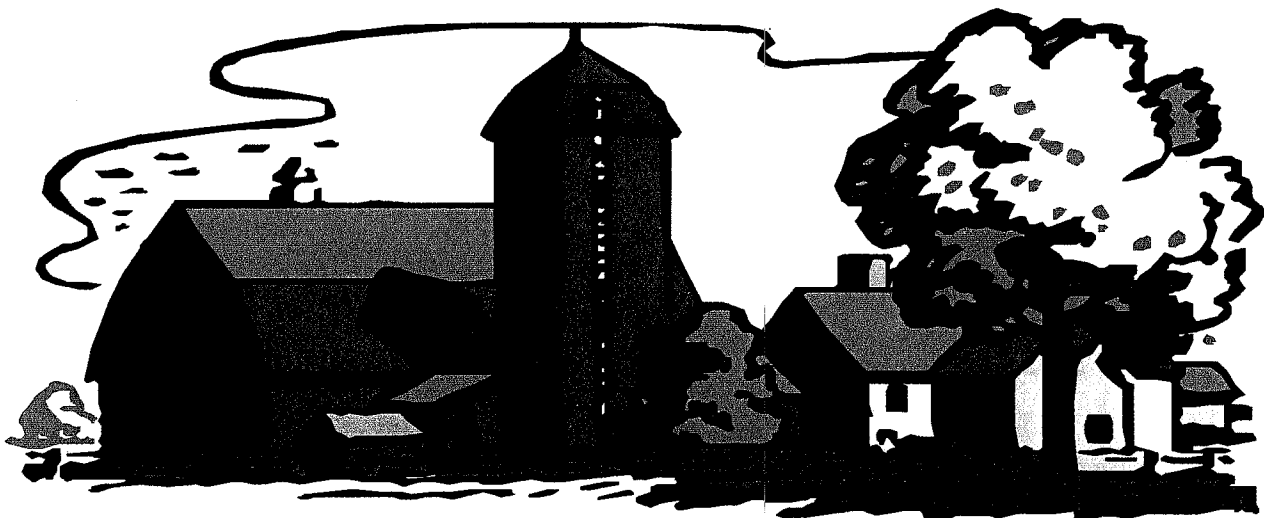

50¢

September 2007

September 2007

Sandia District
Cub Scout Roundtable Staff

<u>Position</u>	<u>Name</u>	<u>Phone #</u>
Roundtable Commissioner	Ken Flack	884-2043
District Executive	Jan Gimar	345-8603
Assistant Roundtable Commissioner		
Pack Administration	Gary Cade	296-4052
	Cynthia Howard	
Cubmasters	David Kesner	830-2064
	John Tucker	883-7704
Webelos Den Leaders	Mavis Gorley	
	Gale Flack	884-2043
Den Leaders	Trish Miller	323-1706
Tiger Cubs Group Coaches	Vicki Metz	
Special Assignments	Beth Bregar	271-1466
Special Projects	Dave Bregar	271-1466
Resource Table	Gale Flack	884-2043
Roundtable Den Chief		
Roundtable Book Editors	Ken & Gale Flack	884-2043

What's Ahead At Roundtable

October 11th
Indian Nations
A Nation of many Nations

Your Sandia District Roundtable Staff
is interested in your comments about your Roundtable.
To electronically contact us, send comments to Kflack4@comcast.net

September 2007

Upcoming Training Events

The Next Metro Day of Training

Sept. 22nd **New Leader Essentials &
Cub Scout Leader Basic Training**
All Position Specific Training
Paradise Hills United Methodist Church

Contact Sandia Training Chair, Beth Bregar, for alternate scheduling

Other Training Dates

Sept. 29th **Baloo Training
(Basic Adult Leader Outdoor Orientation)**
The basic course for planning and & executing Cub Scout outdoor activities. This course is required for leading a Cub Outdoor Experience. Each pack needs at least 1 leader trained in Baloo
*A full day training session
Carolino Canyon Park*

Nov. 3rd **Metro Cub Leader Pow-Wow**
A full day of workshops for new or experienced Cub leaders. Everything you wanted to know about adding pizzazz to your program
Rio Rancho Mid High

Other Important Dates

Sept. 29th **Tiger Cub / New Cub Scout Day**
Get new Cubs involved in fun activities including:
Archery, BB guns, rain gutter regatta, water rockets,
and many, many other exciting activities.
*9 AM until 12 noon
Council Service Center*

Oct. 20th **Scout-O-Rama**

Opening Ceremonies

Farmer's Welcome

Cubmaster enters dressed in overalls or jeans with a plaid shirt, a straw hat, boots, etc.

Welcome everyone, to the farmyard of Pack _____. I'm Farmer _____, the boss around here. I'm really glad you could come visit us tonight. You know, on the farm there is plenty of work to do. Everyone in my family is busy planting seeds, harvesting crops, feeding the animals, and just keeping the farm running. But we are never too busy to help our neighbors in need, or help out at the local church, or even raise the flag down at the town square. That's one thing I like about the Cub Scouts. You are busy with school work, and earning all those fancy awards, and playing with your buddies, but you are never too busy to help when you're needed. I like that line in the Cub Scout promise that says "...to do my best, to do my duty to God and my Country..." You really know how to do your best and do your duty, both to God and your Country.



Will you please rise and reflect on how you can continue to do your duty to God and this great country as we salute the flag and say the Pledge of Allegiance.

Growing Carrots

Equipment: A package of carrot seeds and a few carrots with tops.

- Cub #1:** Inside this package are tiny carrot seeds. They don't look like much because they are tiny and fragile.
- Cub #2:** But if we plant them in good soil and we make sure that they get plenty of sunlight, air, and water, they will grow up to be big, healthy carrots like These.
- Cub #3:** Cub Scouts are like carrots. We need certain things too.
- Cub #4:** Like good food, rest and exercise.
- Den Leader:** But Cub Scouts need something more. They need to have healthy minds and spirits if they are going to be the kind of men we will admire. In Cub Scouting, and later on in Scouting, boys can develop that extra quality of mind and spirit. They do it by following the Cub Scout Promise and later on, the Scout Oath. Will you please stand and join us in repeating the Cub Scout Promise?

Farm Country

Personnel: Narrator and 4 Cubs

Narrator: Agriculture, the oldest work done by man, means "taking care of the fields". It is the work and science of using the earth to produce food.

Cub 1: Farming means about the same thing, but we generally use the term when referring to a particular branch, such as dairy farming,



chicken farming, cotton farming, wheat or vegetable farming. There have been farmers since history began.

Cub 2: Farm life, was quite different in days past. Entire families, including children, had to carry their share of the load in order to raise enough food for themselves. The family did not have much time for comfortable living.

Cub 3: Crowing roosters still announce dawn on many American farms. In the early morning fresh odors of growing crops and blooming flowers fill the air. Even before daybreak, in farm country, lights begin to twinkle as folks rise early to feed the animals and do the chores.

Cub 4: Now in gratitude for the hard working farmers across our land, may we all stand and sing "America the Beautiful."

Opening Prayer

Father, be with us as we work with the boys in our dens and packs. Just as you bring the sun, rain, and other blessings to the farmers, please bring patience, understanding, and knowledge to all of us leaders and parents. Amen.

Closing Ceremonies

Cub Scout Garden of Thought

Setup: Seven Cub Scouts dressed in farmer's hats, shirts, levis, etc., carrying gardening tools and large cutouts of vegetables – carrots, lettuce, turnip, bean, beet, large package of seeds.



Cub #1: We're Cub Scout farmers who've come your way to share with you, our garden of thoughts for the day.

Cub #2: *(Holds up carrot)* Take care at all times, remembering to do our best each day.

Cub #3: *(Holds up lettuce)* Let us always give a smile to others as we travel down life's way.

Cub #4: *(Holds up turnip)* be sure to turn up at meetings and participate in pack activities.

Cub #5: *(Holds up bean)* learn not to put things off – for its not fun being late.

Cub #6: *(Holds up beet)* in life's game, you can beat it if you strive to work with everyone.

Cub #7: *(Holds up large package of seeds)* and now that we've planted some seeds of thought, we'll say good night, for our meeting is adjourned.

Things That Grow

Cub Scout: The theme this month is "Down on the Farm." I, too, am a thing that grows. I need nourishment, and love, and attention to grow. But most of all to grow, I need my sleep.
Thank you everyone, and good night!"

Thank a Farmer

- Cub #1:** When you eat breakfast tomorrow morning, thank a farmer. He grew the corn, wheat, and rice in your cereal. He raised the dairy cows that gave you milk. *(Hold up cereal box and milk carton).*
- Cub #2:** When you eat lunch tomorrow, thank a farmer. He grew the wheat for your bread, the peanuts for your peanut butter, and the fruit for your jelly. *(Hold up a loaf of bread).*
- Cub #3** When you eat a snack tomorrow, thank a farmer. He grew the apples for your juice, and the celery and carrots for you to munch. *(Hold up an apple and a carrot).*
- Cub #4** When you eat dinner tomorrow, thank a farmer. He raised the beef cattle for your hamburger, the potatoes for your mashed spuds, and the lettuce for your salad. *(Hold up a picture of a hamburger or potato or lettuce).*
- Cub #5:** He may live down the street, in the next county, or across the United States. But, wherever he may be, remember—
- All:** **Thank a farmer!**

Cubmaster Minutes

A Crop of Smiles

Once upon a time, two brothers left the farm to move to a city to look for work. Just outside of the city, the first brother met an old man and asked him, "What are the people like in this city?" The Old man replied, "Well, how were they where you come from?" "They are all grumpy and cross," replied the brother. "That's why I decided to leave." "You'll find the people here exactly the same," said the old man as he walked on down the road. A little while later, the old man met the second brother. He too asked, "What are the people like in this city?" The Old man replied, "Well, how were they where you come from?" "They were very nice. They always smiled," replied the brother. "That's why it was so hard for me to leave." "You'll find the people here exactly the same," said the old man as he smiled and joined the second brother on his way.

Remember, we reap what we sow.

Resourcefulness

A farmer has many resources to help him grow healthy plants and animals. Good soil, water, and sunshine are available for him to use. There are scientists who have developed better seeds and stronger animals. Equally important, though, are the resources the farmer has in himself – knowledge, experience, courage, and the ability to work hard. Just like the farmer, Cub Scouts have lots of resources, too. Parents and leaders are important, but it is important that you boys develop resources inside yourselves. Learn all you can, have the courage to try new things, learn to work hard, and do your best, and you will be a success in life.

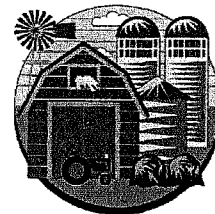

Closing Prayer

For the rich soil in which grows food,
For the harvest large and good,
For animals and plants alike,
We thank Thee, Lord. Amen.



Leader Induction Ceremony

Equipment: 5 candles, candle board with 2 holes in top and 3 holes in bottom

Committee Chair: Before you is a ceremony board that has 5 candles in it. The top 2 like the alert ears of a Wolf, represent the 2 upright fingers of the Cub Scout sign. They mean TO OBEY and TO HELP OTHERS.

The 3 candles at the bottom represent the folded fingers of our Cub Scout sign. These 3 fingers stand for the 3 secret letters in our law – F, H, G. These letters mean FOLLOWS, HELPS, GIVES. They also mean FAIR, HAPPY, GAME. And finally they can remind us of something each Cub Scout respects, FREEDOM, HOME, and GOD.

All of our leaders want to do their best to teach Cub Scouts to learn to follow, to help, to give, to be fair and happy whatever the game might be and to respect their freedom, home, and God.

Will all leaders please come forward? Please repeat after me.

“I, (*name*), promise to do my best, to help the Cub Scouts in my den and in my pack to do their best, to help other people, and to do their duty to God and their country, and to obey the Law of the Pack.”

As chairperson of Pack (*pack number*), I thank you for your active leadership in Cub Scouting. May the days ahead bring you fun and fulfillment.

Advancement Ceremonies

Farmer's Vegetables

Cubmaster: *Dress up in a flannel shirt and overalls, bandana, straw hat and maybe a piece of straw in your mouth. Have a hoe (real or plastic) for the boys to use.*

For each boy who is earning awards, have copies of different types of vegetables, staple around the edges after the awards are inside. Have the boy pretend to hoe up the vegetables, to reap the rewards of what was planted.

Or if you want things a little more 3-D:

Carrot: orange paper rolled into a cone shape (put the awards inside, poke some green leaves out the top, then staple shut.)

Corn: toilet paper tube covered in yellow paper, with little squares drawn on, put some long green leaves around the outside, put awards inside, bring ends to a point and staple shut).

- Potato:** toilet paper tube covered in brown paper, with little eyes drawn on, (put awards inside and staple or tape ends shut).
- Green beans:** Wrapping paper tube, or paper towel tube, wrapped in green with awards inside, bring ends to a point and staple shut.
- The following are good if a den did something together, or to present the same segment or award to a lot of boys:*
- Tomato:** stick awards inside a red balloon and blow up to the size of a tomato. Hang on a dead branch painted green, standing in a pot.
- Peas:** have awards stapled to circles of green paper, (or in between 2 pieces of paper) roll up the awards into a long tube of green paper.
- Apple:** have awards stapled to apple shaped pieces of red paper, (or in between 2 pieces of paper) place the awards in basket.

Farmer's Animals

Have a large drawing of a barn and have copies of different types of farm animals (the type that are in coloring books), staple badges to the back of the pictures, and have the pictures scattered on the floor (or pinned to a board) around the barn, and ask riddles to have the boy identify which animal he needs to 'herd' in.



The Law of the Harvest Ceremony

Materials: *Farmer costume for Cubmaster, hoe or shovel, paper cups, plants from construction paper or plastic plants with each award on the bottom of a plant. Staple each award to the bottom of a plant and place the rank award and plant in each cup. Put crumpled brown construction paper or paper bag around plants to hide the award.*

Preparation: *Create a garden replica near the front and to side of the pack meeting room. Arrange the prepared plants with award to form the garden.*

Farmer: All farmers know the truth taught in scripture "... for whatsoever ye sow, that shall ye also reap; therefore, if ye sow good ye shall also reap good for your reward". This teaching is proven every year at harvest. The farmer plows the soil and plants his seeds in spring. He takes care of his crop by watering, weeding and feeding it all through the heat of summer with the expectation and faith of receiving his reward at the fall harvest. You like the farmer have planted the seeds of knowledge and growth. Through hard work you have earned the rewards of the harvest. Today we will learn some of what your efforts have reaped.

Rank Presentation: *The farmer goes to the garden. Act out collecting the harvest using the hoe or shovel. Kneel down and pull out one of the plants with the award attached. The farmer names the boy with the rank advancement and asks that he and his parents to come up front to the garden. Share some of the things the boy has done to get the award. Ask the boy what he liked best and present the rank to the boy and his parents. Repeat until all the awards are presented.*

Progress in an Egg

Preparation: Need plastic eggs. Badges are placed inside the eggs. Write the name of the boy on the shell. .

CUBMASTER: This month we have been learning about farming. In gratitude for our efforts and to honor our Cub Scouts who have worked so hard this month to earn their awards, the chickens have laid some special eggs.

Each boy is then called up and breaks open his egg to receive his award. For advancements, present the egg to the parents first.

Audience Participations

A Trip to the Farm

CUBMASTER: Do your best! (Cub Scout salute)

DEN LEADER—Now, boys! (Shake finger)

WEBELOS DEN LEADER—We'll be (Stomp feet) Loyal Scouts! (Stomp feet)

SONG LEADER—Encore, encore (Clap hands)

OLD CAR—Chug a chug a chug a (Shuffle feet)

COW—Moooooooooooo (Interlock fingers, turn hands upside down with thumbs extended)

PIG—Oink, oink, oink (Push up the end of your nose)

SHEEP—Baaaaaaa (Wag tail)

Once upon a time, a **CUBMASTER**, a **DEN LEADER**, a **WEBELOS DEN LEADER**, and a **SONG LEADER** were traveling across the countryside in an **OLD CAR**. As the night approached, they passed a farm. Grazing in the pasture were a **COW**, a **PIG** and a **SHEEP**. Rain began to fall as darkness closed in around them. Suddenly the **OLD CAR** stopped dead. Unable to fix the **OLD CAR**, the **CUBMASTER**, the **DEN LEADER**, the **WEBELOS DEN LEADER**, and the **SONG LEADER** walked to the farm where they had seen the **COW**, the **PIG**, and the **SHEEP**. Greeted at the farmhouse door by the farmer, the **CUBMASTER**, the **DEN LEADER**, the **WEBELOS DEN LEADER**, and the **SONG LEADER** asked to spend the night. "Certainly," said the farmer. "I myself have an **OLD CAR** and know how undependable they can be. But I only have room for three in my small house and one of you will have to sleep in the barn with my **COW**, my **PIG**, and my **SHEEP**." "That's okay," said the **CUBMASTER**. "I will sleep in the barn." Ten minutes passed and there was a knock on the door of the farmhouse. When the farmer opened the door, there stood the **CUBMASTER**. "I'm sorry," he said. "But the **COW** made so much noise I couldn't sleep." "I am used to **COWS**," said the **DEN LEADER**. "I will sleep in the barn." Ten minutes passed and there was a knock on the door of the farmhouse. When the farmer opened the door, there stood the **DEN LEADER**. "I'm sorry," said the **DEN LEADER**. "I am used to **COWS**, but the **PIG** made so much racket that I couldn't sleep." "Think nothing of it," said the

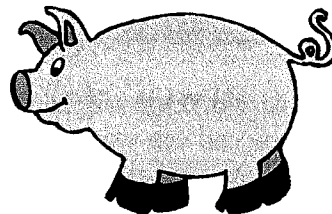

WEBELOS DEN LEADER. "I am used to **COWS** and **PIGS**. I will sleep in the barn." Another ten minutes passed and there was another knock on the farmhouse door. "I am used to **COWS** and **PIGS**," the **WEBELOS DEN LEADER** said when the door opened. "But the **SHEEP** made so much noise that I couldn't sleep." "Then I will sleep in the barn," said the **SONG LEADER**. "But before I go to sleep, I will practice the songs for the next pack meeting." The farmer went to bed for the night. Immediately, there was yet another knock on the door. He got up and opened the door. There stood the **COW**, the **PIG**, and the **SHEEP**!

The Fun of a State Fair

STATE FAIR: "Ya'll come" (*everyone*)
MOM: All ladies stand up
DAD: All men stand up
CHILDREN: All children stand up

If you want to have some fun, for just everyone, go to the **STATE FAIR**,
And before your eyes, will be a surprise at which you can look and stare!

Nothing can compare to the **STATE FAIR**, and what is has store,
For just everyone it can be so much fun, with games and displays galore!

MOM can compare the baked goods there, and marvel at those pies,
She can even bake and enter a cake, and perhaps win the blue ribbon prize.

DAD can have fun as well as anyone, when to the **STATE FAIR** he goes,
He can spend all day at a livestock display, or win a prize with his lucky throws.

CHILDREN can eat every kind of treat that is sold at the **STATE FAIR**
Or they can spend hours on end, whirling on rides through the air.

Whether big or small, there's fun for all, when you go to the **STATE FAIR**.
You can look and play all the livelong day and forget every worry and care.

So **MOM** will try to bake a pie, to enter at the **STATE FAIR**,
Then the noise will be loud from the watching crowd as the judges taste them with care.

With the pies that you bake, first place you will take and we'll all be
filled with pride,
When judges pick your pie, we'll stand up and cry,
we're proud, **MOM**, to be by your side.

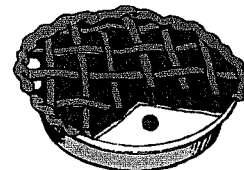

And dear old **DAD** will have fun like a lad as each game of chance he plays
We know you can win, just try it again, you'll have prizes by the end of the day.

All the rides will run till the day is done, and the **CHILDREN** won't care at all

They'll spend their money on a sideshow so funny or on a ride or a trinket so small.

Oh, the **STATE FAIR** is a family affair, with fun there for everyone.
What an enjoyable way to spend a day, until the day is all done!

Skits

The Endless Chicken Jokes

Cub #1: Why did the chicken cross the road?

Cub #2: There was a car coming.

Cub #1: Why did the chicken cross the road halfway?

Cub #2: She wanted to lay it on the line.

Cub #1: Why did the rubber chicken cross the road?

Cub #2: She wanted to stretch her legs.

Cub #1: Why did the chicken cross the twice?

Cub #2: Because he was a double crosser.

Cub #1: Why did the chicken cross the road?

Cub #2: To take the road less traveled.

Cub #1: Why did the chicken cross the road?

Cub #2: Don't ask me, ask the chicken!

Cub #1: Why did the chicken stop crossing the road?

Cub #2: It got tired of everyone making so many jokes about him!

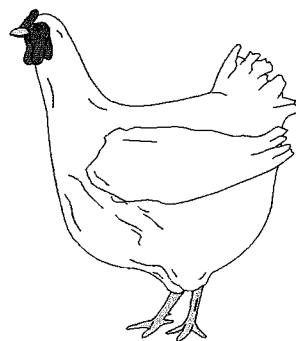

Cat Tracks

Characters: Several Cub Scouts with one scout is looking at something he's looking left and right. Another scout enters and asks what he is looking at. The first scout says cat tracks. Both scouts start following the tracks. Other scouts enter and start to follow. Finally they come upon a bush and something is moving inside it all the scouts gather around the bush.

Cub Scout #: "It's a skunk!"

All scouts run.

The Mice Family

Characters: *Mother Mouse (Den Leader), Mice (Cub Scouts or children), Cat (Den Leader).*

Props: *Make signs for Mother Mouse, Cat and Mice.*

Mother Mouse is taking her children for a walk in the barn. Suddenly the Cat appears in their path.

Mother Mouse: Bow wow wow! Bow wow wow!
The cat shrinks in fear and runs away.
Mouse Children: Oh, Mother, we were so scared.
Mother Mouse: Let that be a lesson to you children. It pays to learn a second language.

Ooooo

Characters: Two Cub Scouts
Props: Two bowls, spoons, table and two chairs.
Both scouts are sitting down eating.

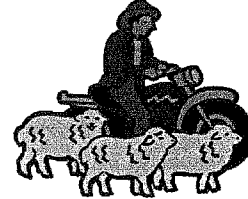

Cub Scout #1: I think my Alphabet soup is spelling out something "OOO" "OOOO."
Cub Scout #2: You're not eating Alphabet soup, you're eating CHEERIOS!

Hayfield

Characters: Three Cub Scouts fishing; one farmer.
Props: Two benches or chairs for a boat.

The three fishermen are sitting in the boat with imaginary fishing poles. The farmer enters and asks

Farmer: Catch anything?
All Fishermen: NOPE
Farmer: Maybe the reason is that you're in the middle of my hayfield and not a lake.
Fishermen: Boys, I think he's right.

Applauses

Hog Calling: SOOOOOOO-EEEEEEEE, SOOOOOOO-EEEEEEEE! Pig Pig Pig !!

Cat: Stand and give a loud "Me-ow" three times.

Turkey: Say as you strut, say, "gobble, gobble, gobble."

Chicken: Bend your arms like wings of a chicken and while moving your arms up and down, cackle like a chicken ("bok bok bok").

Clapping Furrows: Have one boy or person in each row or section start this one. They will clap twice and then clap the hand of the person next to them. Continue to clap in unison in this manner until everyone in the room is clapping.

Heavy Veggie: "Squash, squash, squash."

Potato: "Mash, mash, mash."

Tractor: Pretend to start up an old tractor by making a sputtering sound to a putt – putt (show hand gestures by turning a crank).

Mule: Hee haw, hee haw, hee haw

Cow: Pretend to milk the cow, saying, "Squirt, squirt, squirt."

Hay & Straw: Divide the group into two sections. Tell one group that when you point to them they are to yell, "HAY!" Tell the other section to yell, "Straw!" Vary the speed in which you point to the different groups. Variation: When the leader yells, "Hay!" or "Straw!" the audience responds with the opposite word.

Barnyard Howl: Have each den pick a farm animal. When the Cubmaster yells, "Down on the farm", pointing at each den in turn, which makes the noise of its animal. Cubmaster yells, "One more time," and all dens make their sounds at the same time.

Run-ons

Cub #1: What has 2 legs and wings but doesn't fly?

Cub #2: Chicken

Cub #1: What has 4 legs, 2 horns a tail and flies?

Cub #2: A cow

Cub #1: What has a mane, a ponytail and shoes?

Cub #2: A horse

Cub #1: What has no legs, no wings but a long tail?

Cub #2: A snake

Cub #1: What do you call someone who is smoothing down pieces of corn?

Cub #2: Kernel Sanders

Cub #1: Why did the horse sneeze?

Cub #2: Because it had a little colt.

Cub #1: I crossed a chicken with a banjo.

Cub #2: What did you get?

Cub #1: Something that plucks itself.

Cub #1: How do you turn a pumpkin into another vegetable?

Cub #2: Throw it in the air and when it comes down, its squash!



Down on the Farm Theme

If the family can share the great outdoors or enjoy wildlife, then why not visit a farm to see how it operates? This month the Scouts will understand cooperation when learning about farm life and how a family farm operation runs. Find out how the fields are watered, how the crops are planted, and how the fields are harvested. Den leaders not only teach about farm life, but actually take a field trip to a farm. See the animals. Ask if the scouts can help feed the chickens and gather the eggs. Try milking a cow and feeding the pigs. At pack meeting let the cub scouts tell of their experiences. Let the Cubmaster dress as Farmer Brown, maybe carry the awards in an old milk bucket. End the evening with homemade bread and fresh churned butter.

Den/Pack field trips: Dixon apple farm, pumpkin patches, hayride, or a farmer's market, State Fair, farm, dairies, harvest festival, pumpkin decorating (contest)

Pack Harvest Festival – see "Autumn Harvest Festival" in the *Cub Scout Leader How-To Book*. Brainstorm ideas: where to have it, what activities to have, how to involve the families in planning, etc.

Spiritual growth: boys will gain new understanding of God's creations as they see the wonders of plants and animals.

Fun and adventure: boys will have fun as they see farm animals and explore the grounds and building of a farm or at the State Fair

Character development: boys will learn patience and responsibility while working with animals and plants.

Core value: Resourcefulness – boys will see that farmers need to make use of many different resources to be successful in raising animals and plants

HARVEST FAIR MIDWAY IDEAS:

Pumpkin Decorating Contest - using paints!

To preserve the pumpkins, paint the faces and use a clear varnish/shellac to keep the paint from chipping off.

Pumpkin Toss

6 pumpkins about the same size/or plastic balls, 6 ping pong balls, masking tape

Carve the pumpkins or use the plastic pumpkins. Put them directly behind each other in a line. Mark them each with a number, 1-6. Mark with the tape, beginning line. Have the cub toss the ball into the first pumpkin...then the second, the third, etc. If the cub misses, his turn is over and the next cub tries. You can also put points on each pumpkin and add up the total at the end of a turn.

Potato Sack Race, Egg Toss, Bean Drop, Hog Calling Contest, Cake/Pie Walk, Bobbing for Apples, Watermelon Eating Contest (no hands!), Watermelon Seed Spitting Contest, Cake/Pie Contest (best looks, funniest, etc.)

Milk the Cow – see *Games*



Songs

GHOST CHICKENS

(Tune: Ghost Riders in the Sky)

A chicken farmer went out
One dark and dreary day,
He rested by the coop
As he went along his way.
When all at once a rotten egg
Hit him in the eye,
It was the sight he dreaded...
Ghost chickens in the sky!

Chorus:

Bok, bok, bok, bok,
Bok, bok, bok, bok,
Ghost chickens in the sky!

The farmer had raised chickens,
Since he was twenty-four,
Working for the colonel
For thirty years or more.
Killing all those chickens
And sending them to fry,
Now they want revenge...
Ghost chickens in the sky!

Chorus

Their feet were black and shiny,
Their eyes were burning red.
They had no meat or feathers,
Those chickens all were dead.
They picked the farmer up
And he died by the CLAW!
They cooked him EXTRA CRISPY,
And served him with cole slaw.

Chorus

WE ARE PLANTING

(Tune: Are You Sleeping?)

We are planting, we are planting,
Garden seeds, garden seeds,
Vegetables are growing,
Vegetables are growing,
Hoe the weeds, hoe the weeds.

MULES

(Tune: Auld Lang Syne)

On mules we find two legs behind
And two we find before;
We stand behind before we find
What the two behind be for.
When we're behind the two behind
We find what these be for;
So stand before the two behind,
And behind the two before.

TOMMY HAD A SWARM OF BEES

(Tune: Mary Had a Little Lamb)

Tommy had a swarm of bees,
Swarm of bees, swarm of bees.
Tommy had a swarm of bees
Whose hive was full of honey.

And everywhere that Tommy went,
Tommy went, Tommy went,
Everywhere that Tommy went
He sold the honey for money.

CHICKEN SONG

(Tune: Turkey in the Straw)

Oh, I had a little chicken
And she wouldn't lay an egg.
So I poured (**hot water**)
Up and down her leg,
And the little chicken hollered
And the little chicken begged
And the little chicken laid
A (**hard boiled**) egg.

2nd verse: chocolate, chocolate egg

3rd verse: Easter egg dye, Easter egg

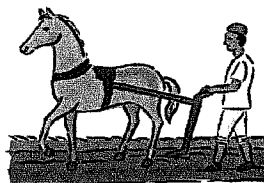

Gathering Games



Animal Name Game

Put the correct letter in front of the appropriate space.

- _____ 1. adult female horse
- _____ 2. adult male goat
- _____ 3. a horse not yet a year old
- _____ 4. baby cow
- _____ 5. young male horse
- _____ 6. adult male duck
- _____ 7. baby pig
- _____ 8. adult male chicken
- _____ 9. young duck
- _____ 10. young goat
- _____ 11. adult male horse
- _____ 12. adult female pig
- _____ 13. adult male cattle
- _____ 14. adult female sheep
- _____ 15. young chickens or turkeys

- A. piglet
- B. rooster
- C. calf
- D. drake
- E. colt
- F. mare
- G. buck or billy
- H. foal
- I. ewe
- J. poults
- K. kid
- L. duckling
- M. stallion
- N. sow
- O. bull



Fill in the Blank Farm Puzzle

3 letters
COW

8 letters
TOMATOES

4 letters
BARN
CROW
NEST
ROPE
SILO

9 letters
FARMHOUSE

5 letters
STALL

6 letters
GARDEN
HORSES
PIGSTY
SQUASH

7 letters
CARROTS
LETTUCE
ROOSTER
TRACTOR



Answers: 1-F, 2-G, 3-H, 4-C, 5-E, 6-D, 7-A, 8-B, 9-L, 10-K, 11-M, 12-N, 13-O, 14-I, 15-J

Games



Two by Two

Prepare duplicate list of names of animals on a piece of paper. Give each boy one of these slips of paper. After everyone has an animal name, they must make the sound of that animal until they find their matching animal. Be sure to pick animals that the boys can make the noise. (A fun prank for one of the leader's who is a good sport, is to give him or her an animal that has no match. Then at the end of the game he or she is the only one making an animal sound.)

Chicken Stretch-

***DO NOT REVEAL THE NAME OF THE ACTIVITY
UNTIL AFTERWARDS! IT RELIES ON AN ELEMENT
OF SURPRISE. (GREAT FOR PACK MEETING)***

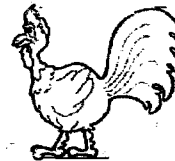

Have everyone form a circle. Explain that it is important to warm up one's body from head to toe before participating in physical games and activities. Starting with legs, ask people to try to get their knee to touch their chin. Try each leg alternately. Ask for 10 knee to chin touches. It is not easy, some can do it, and many can't. Encourage every one to at least try. Then move to the arms. One side at a time, stick thumb under armpit and raise arm up and do a side stretch. Three times on each side. Then explain that it is important to warm up one's vocal cords for group games. Ask them to make different barnyard noises ending up with turkey or chicken noises. Finally, put it all together - demonstrate and encourage - walking around raising knees in air, flapping both arms and making animal noises (at some point start encouraging the chicken noises) and you have a bunch of warmed up, feeling silly cub scouts and parents.

Egg Drop

Have the boys bring a prepared container from home, which could protect an egg when dropped from a height of several feet. An adult could drop them from a 12 ft. ladder, cherry picker, roof, or other pre-determined high spot, one at a time. Then open the containers and see whose egg survived.

The Farmer and the Crow

Materials needed: 6 items such as beanbags, paper cups, fun foam squares, etc. for each team

Divide the cubs into teams of equal numbers. Each team stands behind a starting line facing a wall or finish line about twenty feet away. The first player on each team is a farmer, the second player is a crow, the third a farmer, the fourth a crow, and so on. At a signal, the first farmer on each team takes the seeds (six items) and places them at equal intervals from the starting line to the finish line. He runs back and touches the second player, a crow. The crow must hop over each of the seeds, touching the finish line, change to the other foot, and hop back, picking up each seed as he comes to it. He hands them to player number 3, a farmer, who goes out to plant them again, and so on. The team finishing first wins. If there is enough time, play the game again letting each crow be a farmer.

Horse

Play Horse with a basketball and hoop. Player 1 takes the basketball and makes a shot. If he succeeds, others then try and duplicate the shot from the same spot. A missed shot earns an "H". Player 2 then takes a shot, and play follows in similar fashion, with misses adding letters to spell out "HORSE". The game starts over when "HORSE" is spelled out.

Vegetable Regatta

A vegetable regatta is just like a raingutter regatta, except that you use vegetables instead of the regatta kit. Boys choose the type of vegetable they want and carve it to make a boat. Sails can be added using toothpicks.

Parent and Son Milking Contest

Make a cardboard cutout of a cow. Attach water-filled rubber glove with pinholes in the fingers. Set a bucket to catch the "Milk." Set a time limit for each "Milker"

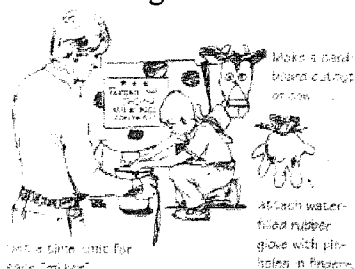

Feather Race

Materials: Feathers, Straws, Tape, Flat surface

On the flat surface tape two lines on for the start and one line for the finish. Each scout gets one feather same size and one straw. Have them blow from one end of the surface to the other. Another way you can play is to see who can keep their feather in the air the longest without touching anything.

Chicken Egg Race

Materials: Hard boiled eggs, Spoons Different sizes

Give the scouts the small spoons with one egg and the smaller children the larger spoons with one egg. This game can be played different ways. You can have a start and a finish to where the scouts have to run to the finish line, but if they drop it they have to start all over again and the smaller children can walk to the finish line. Or have them line up in two lines and pass the egg from scout to scout without dropping it.

Hog Tying

This is to help scouts learn their knots

Materials: Rope cut in lengths of about two feet (or cut to your liking), Branches.

Give the scouts a couple pieces of rope each. Have them practice the different knot from the bear/webelos book. The scout who can tie the most knots wins.

Water Trough Baseball

Equipment: Access to water, Hose, Buckets (big enough for a big foot to fit in) or wading pools, baseball bat, balls (baseball soft or water splash balls), sprinkler.

Set up the bases with the buckets/pools fill with water. Set up home base will be the sprinkler next to a bucket/pool filled with water. When a scout is up to bat, just as he swings turn on the sprinkler and see who can hit the ball.

Animal Scramble

When everyone comes into Pack meeting, give each person a name of a variety of five different kinds of animals, in the attempt of attracting the others of their kind. When you find others of your species, take their hands. Continue to make the noise until everyone is gathering together.

Spell That Animal

Have several copies of letters of the alphabet. Place cards out on the tables in front of the each groups. Call out a name of an animal and have them try to spell it out in the correct order within a minute time frame.

Vegetable Stew

Cub scouts are seated in a circle with 1 boy in the center. Leader assigns the name of a vegetable to each of 2 or 3 boys in the group. The leader then calls out a vegetable (corn, peas etc.) the boys are to exchange places, while the boy in the center tries to get one of vacant places. When the leader calls "vegetable stew" everyone scrambles to get a different seat. The one left standing is "it" for the next round.

Harvest Fair

Each Den can provide a booth to provide a fun experience for all. Dens rotate through the booths to complete the activities. Use a special farm sound (such as a cow bell) to advance groups through the booths.

Making Butter

Wash film canisters before pack meeting. Purchase heavy whipping cream or cream. Pour a small amount into the film canister, secure the lid, and have the Cub Scouts shake it for approximately 10 minutes. When they open the canister up, they'll find that butter has separated.

Guess-the-Weight Game

Have an oversized vegetable, or someone's pet. Boys try to guess the weight.

Bread Dough

A demonstration of rising bread dough is an interesting sight. Cub Scouts will enjoy kneading the dough, too. Some families may be willing to make a loaf of fresh bread and bring it so the boys can spread their film canister butter on it to taste.

Hay Dive

Scatter coins or wrapped candies into hay on the floor. Boys jump in and find them.

Scarecrow Building Contest

Cub Scouts bring old clothes and build a scarecrow form them. Then donate the clothes to charity.



Crafts

Neckerchief Slides/Magnets

enlarge or decrease size of patterns as needed

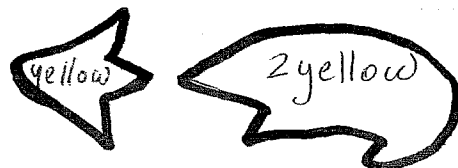
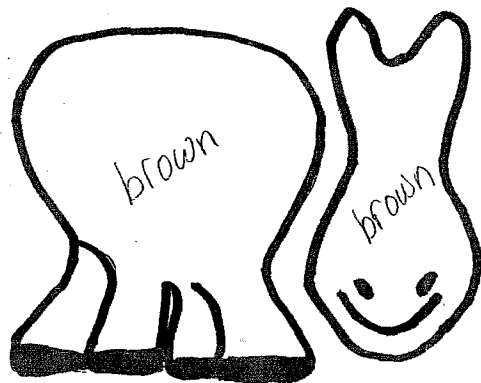

Horse Slide/Magnet

Brown and yellow fun foam, marker, 2 wiggle eyes, scissors, glue, slide backing

Cut out horse body and head from brown fun foam, 2 yellow hair, 1 yellow top knot hair. Using marker, make smile and nostrils, hooves and leg markings. Glue 1 piece of horse hair behind horse's rear and the other behind his head as shown. Glue the other piece of top knot hair between the ears and over his forehead. Glue on 2 wiggle eyes. Glue head to body and slide backing/magnet to entire backside of horse.



Cow Slide/Magnet

Black and white fun foam, marker, 2 wiggle eyes, scissors, glue, slide backing

Cut out white body and using marker, make hooves and spots. Cut out 2 horns, udder, muzzle, and top knot hair from black. Using white marker, make 2 nostrils on muzzle. Cut face from white. Glue horns behind head/ears and top knot hair between ears. Glue on 2 wiggle eyes. Glue head to body and slide backing/magnet to backside.

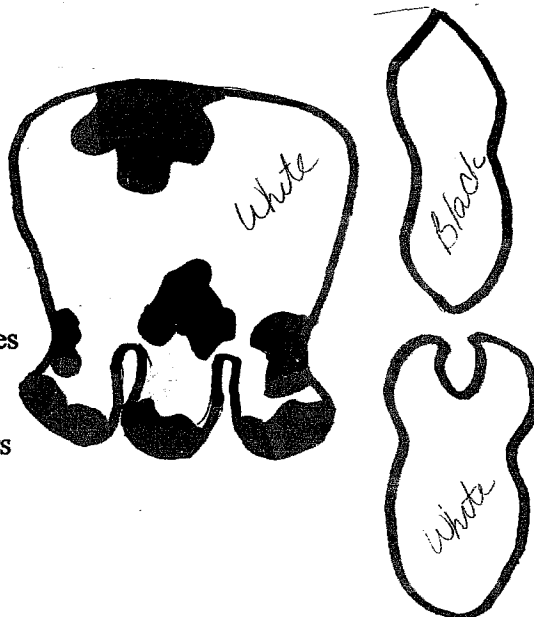

Pig Slide/Magnet

Black and pink fun foam, piece of pink pipe cleaner, marker, 2 wiggle eyes, scissors, side backing

Cut out body, head, and snout from pink. Cut out 2 hooves from black. Using marker, draw in markings for ears, mouth, and eyebrows. Glue 2 wiggle eyes to face. Glue black hooves to bottom of feet. Using marker, make 2 dots for nostrils on snout and glue on face. Curl piece of pipe cleaner for tail and glue to back of body. Glue head to body and slide backing/magnet to back of body.

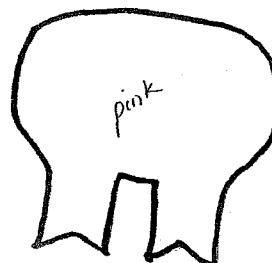
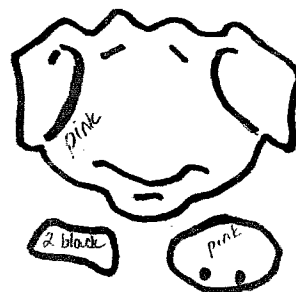

Other Crafts

TP Roll Puppets

Glue a jumbo craft stick inside an empty toilet paper tube. Paint the animal face or decorate with construction paper. Cut out ears and glue in place. Glue on wiggle eyes. Draw on details with marker. The web site below offers several full-sized patterns for farm animal TP puppets, such as cow, bull, donkey, chicken, farmer, etc. They also have paper bag puppet patterns for farm animals and many other animal crafts.

<http://www.dltk-kids.com/animals/farm.html>

Earthworm Terrarium

Set a tin can inside a quart jar. Fill the space between the can and the jar with rich black soil. Press soil down as you go, and fill to about an inch from top of can. Add light colored sand to cover top of tin can. Add a couple of worms. Cover outside of jar with black paper. Remove black paper to see the worms at work.

Baby Food Jar Animals

Paint clean baby food jars or fill with pompoms to match your animal's face. Put on painted lid to match and turn it upside down. Glue on wiggle eyes. Cut ears (or beak) out of craft foam or colored construction paper and glue in place. Add pompoms if desired. For whiskers, cut pieces of craft lace and glue one end under pompom nose. Cut a strip of craft foam ¼" wide and glue around edge of lid.

Sprouts to Watch

Materials needed: blotter paper (buy at office supply stores), water, beans soaked in water for three hours, quart size jar.

Roll the blotter paper to fit the jar. Cut off excess on top. Pour some water in the jar and wet the blotter paper. Press wet blotter paper to the side of the jar so it sticks. Empty out excess water. Pull blotter paper carefully, a little at a time, away from the jar and drop in seeds. It doesn't matter how the beans are turned. In fact, if they are turned sideways or upside down, they are more exciting to watch. Gently push blotter paper back against jar. Add 1 inch of water to the jar so that the bottom of the blotter paper is always kept in water. Add water as this evaporates.

Washcloth Bunny

Materials needed: white washcloth, small pink pompom, small white pompom, two 10mm wiggle eyes, scrap of craft foam, glue gun or tacky glue.

Lay the washcloth on the table diagonally so it looks like a diamond. Beginning at the top point, roll down the washcloth to the middle. Roll the bottom up to the middle. Fold it in half so you have a long strip. Fold the strip in half. Bunch up near the ends to make a head, tying a pipe cleaner around the bunch to make a head. Fluff the ends to make ears. Glue on facial features and tail.

Potato Cows

For each cow find a large potato for the body and a small one for the head. Use cocktail sticks, toothpicks, or matchsticks for the legs and neck. Gently push one end of a string tail into the potato and fray the other end. Paint white spots on the head and body and a black nose and eyes. Use pipe cleaners or pieces of matchsticks for horns.

Egg Shell Mosaics

Paper-mache or cardboard container, egg shells, white tacky glue paint.

Cover paper-mache container top with a thin layer of tacky glue. Take a chunk of egg shell and press it into the glue until more cracks show up and the shells stick. Continue pressing shells to cover the whole surface, then let the glue dry. Paint desired colors over top of the eggshells. While still wet, take a paper towel and gently wipe shells. This takes most of the color off the shells but leaves color in the cracks and creates the mosaic effect. Finish painting the cardboard or paper-mache container, then spray or paint a coat of varnish over container to make it more glossy if desired.

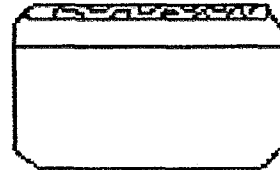
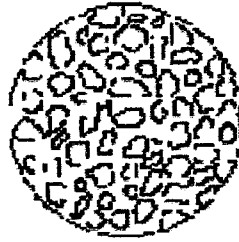

CD Farm Animal Puppets

Old CD's felt or craft foam thin cardboard Popsicle sticks
Wiggle eyes markers glue tape scissors

Cover CD with appropriate color material for animal to be made. Cut out head, ears, and legs for the animal and glue to thin cardboard and then to the CD. Glue on wiggle eyes and draw other features with markers. Decorate as needed. Glue or tape a Popsicle stick on the back.

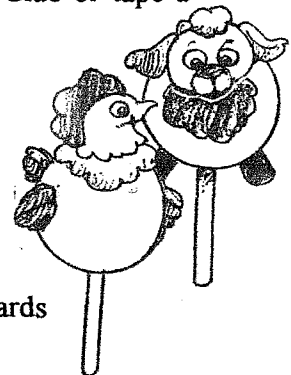
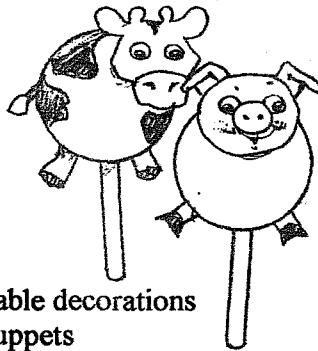

Treat Boxes

Hold candy
Diorama figures

Table decorations
Puppets

Name places cards

HOW TO MAKE – enlarge pattern to size desired

Copy “empty” box pattern onto cardstock enlarging to desired size. Draw tail or body figure onto pattern box. Draw animal head, front feet, body parts, etc. onto cardstock – Do not attach to box. Refer to turkey pattern & boy for size and “3-D” look. Color and cut out all parts. Fold box along solid lines. Use transparent tape to hold tabs in place. Tape head, feet, and body parts into place. Add any additional “parts” desired. (Photo into face!) Fill box with treats.

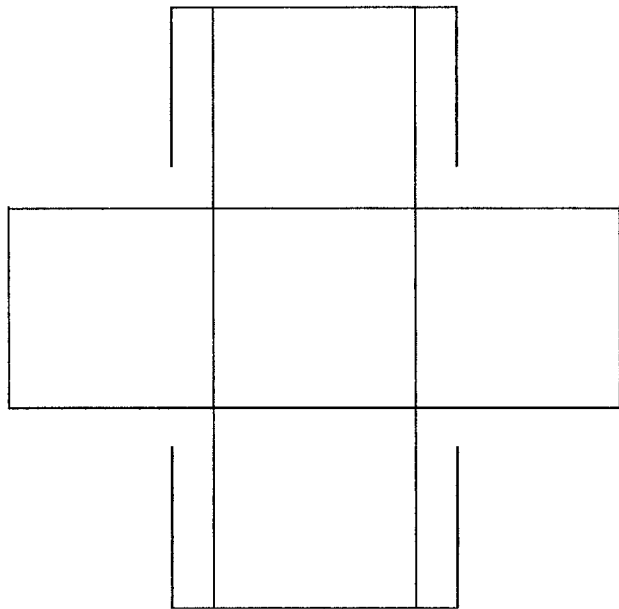
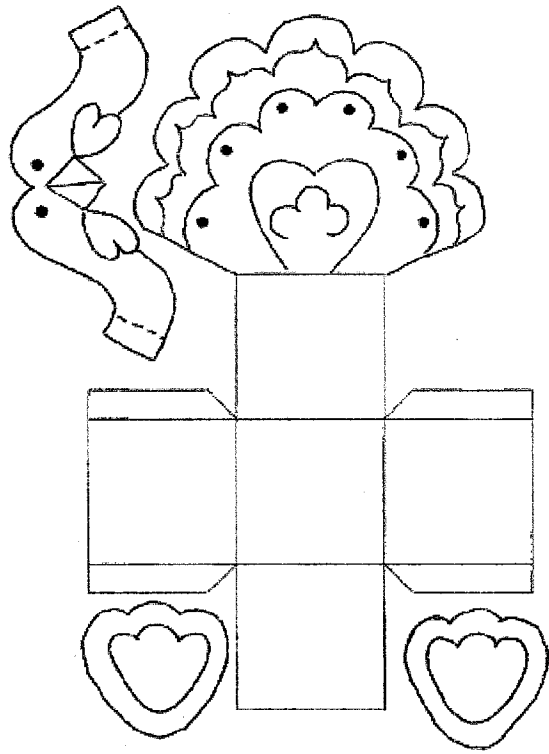
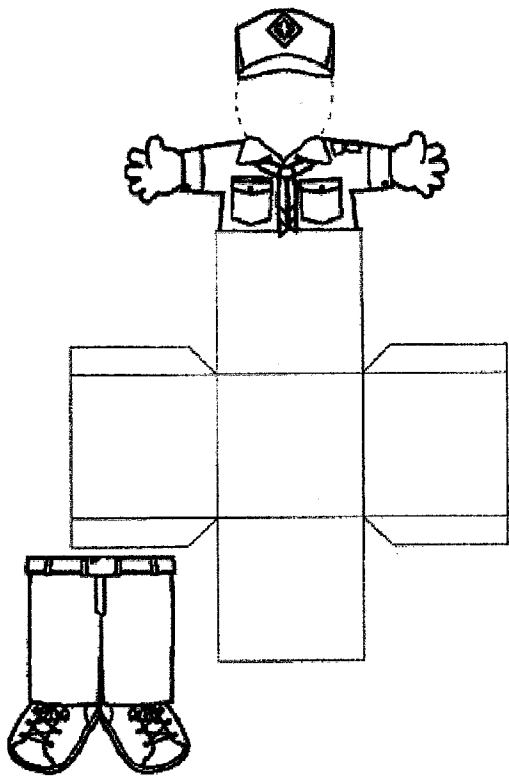

3-D Paper Plate Art or Puppet Theater

Two paper plates for each boy Colored pencils Scissors
Glue Optional: small animal stickers placed on craft sticks for puppets.

Turn one plate wrong (convex) side out and draw a foreground scene. With scissors, cut away where the sky would be. (See example). Turn second plate (concave) and draw background scene. When artwork is done, glue plates together at seams unless you want to make it a small theater. In this case trim away some of the rim of concave plate. Put stickers on craft sticks and put them up between plates for theater.

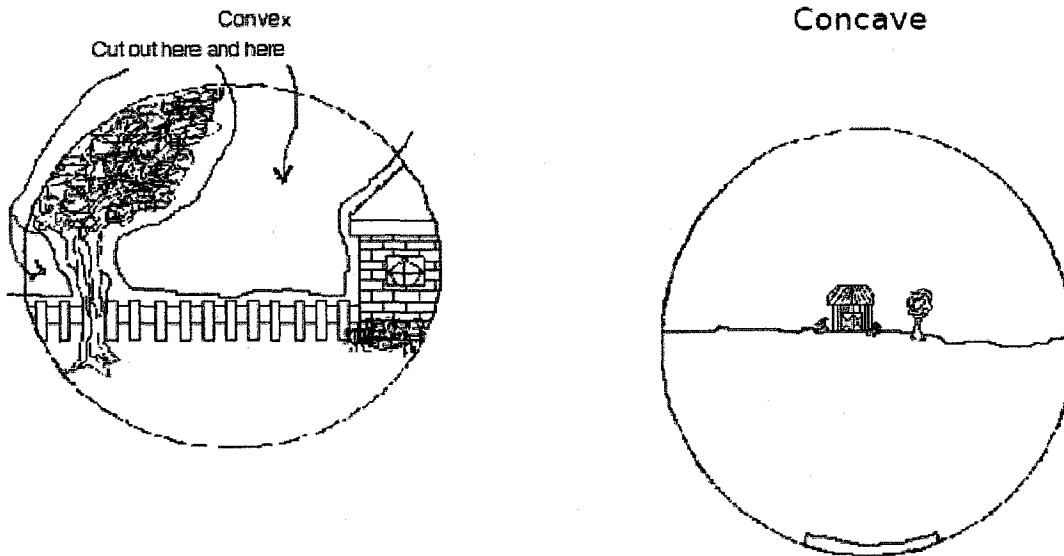

Potato Block Printing

Cut a slice of potato that is flat. Trace a simple design. Using a knife (leaders for younger boys), cut away potato around the design, leaving the raised design about 1/8" high. Press potato on ink pad and then onto paper to print (or use jar lid and paint). Can use sponges or other vegetables, too.

Can use the block printing for: spots on a cow costume, background material for a skit, decorate a booth at the Harvest Festival, and many more ideas!

Homemade Butter

Need one empty quart jar with tight-fitting lid, 1 pint heavy cream, pinch of salt or dab of honey (optional), strainer, bowl

Pour the cream into the jar leaving a space at the top to allow for shaking. Shake the jar until chunks of butter start to form (about 10-15 minutes). Pour the chunks and liquid into a strainer positioned over bowl. Spread butter on bread or muffins for a snack! Add a bit of salt or honey for more flavor.

Cooking with Cubs



Baggie of Mud (Fudge)

4 Tbsp Powdered Sugar 1 Tbsp Margarine 2 tsp of Cream Cheese
1/2 to 1 tsp Vanilla Resealable Plastic Baggie

Place all ingredients in a plastic bag. Squeeze the air out and seal it closed. Blend all the ingredients together by pressing the bag with your fingers. When mixture is well blended, you may add raisins, peanut butter or nuts.

John Deere Fizzle

Use green Kool Aid and Seven up

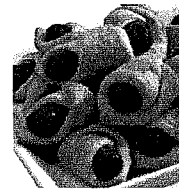

Pigs in a Blanket

Roll of Crescent rolls package of hot dogs
Roll the Crescent rolls around the hot dogs and

oven at 375 for 12-16 minutes or until rolls are golden brown OR use

32 Hillshire Farm Lit'l Smokies® instead of hot dogs
Serve warm with ketchup and mustard, if desired

bake in the

Down on the Farm Dessert Haystacks

6oz package of chocolate Chips 6oz package of butterscotch Chips
3oz package of chow mien noodles

Put waxed paper on a cookie sheet. Combine the chips in a 2 QT pan. Stir over low heat to melt. Stir and melt for 30 seconds. Gently blend in noodles. Stir to coat all noodles. Spoon onto waxed paper and let set until cool. Makes 20 small haystacks.

Animal Chips

1 large tortilla Cooking Spray Salt

Use animal-shaped cookie cutters to cut shapes from a large flour tortilla. Arrange the animals on a baking sheet. Lightly coat them with cooking spray and sprinkle them with salt. Bake at 350° for 5 to 7 minutes and your chips are ready for a dip in salsa or guacamole.

Purple Cow

Vanilla ice cream Grape juice Lemon lime soda

Drop a scoop of ice cream in a clear cup. Pour the juice and soda on top.

Turkey Cookie

Chocolate Wafer Cookie, Chocolate Frosting, Candy Corn
Malted Milk Ball or Mini Peanut Butter Cup
Fruit Roll-Up Candy Sprinkles

Spread the chocolate frosting on the cookie. Place the malted milk ball or peanut butter cup on the frosting (figure 1). Place the candy corn around the malted milk ball (figure 2). Cut shapes out of the Fruit Roll-Up to be the turkeys' beak and waddle. Stick them on the malted milk ball or peanut butter cup using the frosting as 'glue'. Cut feet out of the Fruit Roll-Up and attach to the cookie with the frosting. Use candy sprinkles for the eyes.



Figure 1



Figure 2





COULD YOU BECOME A CITIZEN?

1. Who discovered America and what was he looking for?
2. What were the first 13 original states which formed the Union?
3. How many amendments to the Constitution have been made so far?
4. What must be done before the Constitution can be amended?
5. What right is provided in the 15th Amendment?
6. When was the Constitution of the United States adopted?
7. What form of government do we have in the United States? What is the difference between a republican type of government and a monarchy?
8. How many Presidential electors does each state have?
9. What is the most important right that the Constitution give us as Americans?
10. What are the first 10 amendments to the Constitution called?
11. Who established the first permanent colonies in North America?
12. What is meant by referendum?
13. What are the colors of the United States flag and what do they stand for?
14. Who was President during the Civil War and about when was this war fought?
15. What document was signed on July 4, 1776: where was it signed and what did it declare?
16. What are the basic principles of the U.S. Constitution?
17. Who is eligible for the office of President or Vice President?
18. When and where does Congress meet?
19. Why is the government divided into three branches?
20. How many members are there in the Supreme Court? What is the term of office for these judges?

Taken from the Basic Guide to Naturalization, published by the Immigration and Naturalization Service of the United States Department of Justice

ANSWERS TO CITIZENSHIP QUESTIONS

1. Christopher Columbus discovered America in 1492. He was looking for a short route to the Orient.
2. Connecticut, Delaware, Georgia, Massachusetts, Maryland, New Hampshire, New Jersey, New York, North Carolina, Pennsylvania, Rhode Island, South Carolina and Virginia.
3. Twenty-six amendments have been made so far.
4. Both Houses of Congress must pass the amendment, and 36 states must ratify and approve it.
5. The 15th amendment gave all American citizens the right to vote, regardless of race, creed, or color.
6. The Constitution of the United States was adopted March 4, 1789.
7. A republic. In a republican form of government the supreme power rests in all citizens entitled to vote and is exercised by representatives elected directly or indirectly by them and responsible to them, while in a monarchy the head of the nation is a line who inherits the throne.
8. Each state has as many Presidential electors as it has United States Senators and Representatives.
9. It gave us Equality before the laws regardless of race, color, or religion. It gives us freedom so long as we do not interfere with the rights of others.
10. The Bill of Rights.
11. The English were first with permanent colonies.
12. Referendum means that people may ratify or annual acts of the legislature.
13. Red is for courage, White stands for truth, and Blue is for justice.
14. Abraham Lincoln was President, 1861 - 1865.
15. The Declaration of Independence, signed at Philadelphia. Declared our independence from England.
16. Liberty, Equality, and Justice.
17. A native-born American citizen who is at least 35 years old.
18. Congress meets in Washington D.C. on January third of each year.
19. To provide a system of checks and balances to prevent any group from becoming too strong.
20. There are nine Justices in the Supreme Court. They serve for life with good behavior.

THINGS THAT YOU DO FOR YOUR GOVERNMENT

- Pay taxes ➤ Sit on jury
- Vote ➤ Serve in public office

THE REASON WE HAVE GOVERNMENT

- To provide an orderly system of living together, where we do not infringe on each other's rights.

WAYS THAT YOUR FAMILY HELPS PAY FOR GOVERNMENT:

- Sales Tax ➤ License Tax
- Income Tax ➤ Fines
- Property Tax ➤ Gasoline Tax

WAYS THAT OUR COUNTRY WORKS WITH OTHER NATIONS:

- Membership in the United Nations
- An exchange of ambassadors and ministers
- Membership in international organizations, such as inerpoll!
- Extradition proceedings for criminals (Returning law-breakers to the country in which they broke the law.)
- Tariff laws (Laws which control goods going out of and coming into a country.)

CITIZENSHIP THROUGH SERVICE

One way to make this activity badge come alive is through service. Stress the meaning of citizenship by practicing helping others. Plan a citizenship project. Make sure the project is well planned before you start. Share with the boys that warm feeling of citizenship through service.

- Clean up a park or sponsor grounds
- Fund-raiser for a charitable organization
- Hold a clothing or food drive
- Provide food for a meal for the homeless
- Make gifts for a children's home
- Adopt a senior citizen for a day or a season
- Make decorations for a senior citizen home

YOUNG PEOPLE'S BILL OF RIGHTS

Regardless of race, color or creed The right for me to have:

1. The affection and guidance of understanding parents.
2. A decent home in which I may be adequately fed, clothed and sheltered.
3. Religious guidance and training.
4. A school program which offers me opportunity for development to my full potential.
5. Constructive discipline for the development of good character, conduct and habits.
6. Security in my community against influences detrimental to proper development.
7. The individual selection of wholesome recreation.
8. Life in a community in which the well-being of children is considered of primary importance.
9. Good adult example.
10. A job for my ability, training and experience.
11. Protection against physical or moral employment hazards which make wholesome development difficult.
12. Health services to prevent and treat disease and to permit my mental, physical, and social development

AS CITIZENS, WE CAN OR SHOULD:

- Worship where and how we want
- Say what we think (The cleaner the better.)
- Vote for people we want in office
- Work where we want, purchase items
- Help the police and others
- Help change bad things to become good

Along with being a citizen, there is a great symbol to remind us of the freedoms and opportunities we have in this great Country. Following are some pictures of the history of the United States flag:

Showman



Showman requires you to choose six activities of your choice from any of the three different areas: Puppetry, Music, & Drama. Additionally, one more from each of the three areas must be completed.

** For very shy boys – can tape a one-person skit at home to show at meeting OR have boy wear a costume so he isn't "himself" when he is acting, but someone else OR be a puppet-master !*

Puppetry

Making puppets can be really fun. Here are a few ideas. Try plastic spoons, Eskimo finger masks and paper bag puppets. There are a more ideas out there than you can think of. Have the boys decorate them with wiggles eyes, yarn for hair, material or paper for clothes. Use Magic markers, paint, construction paper, fun foam, felt, etc. Follow these three basic rules for a great puppet show:

#1 - Think short - Remember most of the audience is young. Shows that are short and packed with a lot of action are better.

#2 - Think simple - This applies to everything in the show: characters, props, scenery, parts and action. Have fun doing this and it will be successful.

#3 - Think contrast - Tall character next to short ones, happy next to sad, small movements next to fast action ones. Keep the boys busy and the audience entertained.

Stages: Try using tables turned on their side, refrigerator boxes cut at the top or at the bottom, with an added string and material across, to create a curtain. Make it look like a storybook or a television. Paint on scenery, glue on scenery cut from colored paper. Make different scenes on paper that you fold over as the story changes. You can make this as simple or as elaborate as you and the boys want. Remember K.I.S.M.I.F (Keep it simple, Make it fun.)

See Crafts for CD Puppets

Eskimo Finger Masks

Pencil, 3" x 6" piece of corrugated cardboard, scissors, poster paint, markers, feathers and glue

The Eskimos believed they'd have good luck if they pleased the spirits. They held festivals and made special finger masks to win the favor of these spirits. Finger masks were small, carved pieces of wood decorated with feathers and fur. The carvings represented areas where the Eskimos wanted lots of good luck. Make a finger mask with pictures or symbols representing baseball, school, music or whatever else is important to you.

1. Pencil a 2-inch circle or square onto the corrugated cardboard. Add a small rectangle about half the size of the circle or square at the bottom. Draw two finger holes on the rectangle.

2. Carefully cut out the shape of the finger mask and the finger holes. It's easiest to punch one blade of the scissors into the holes first, then to snip away the rest of the hole.

3. Trace the finger mask onto another piece of cardboard and cut it out the same way. Now you have a matching pair. One for each hand.

4. Pencil in the facial features on the front of each finger mask. They can be human or animal features, or they can be bizarre and abstract. Cut out slits for the eyes and the mouth if you like.

5. Paint the faces on the finger masks. The Eskimo most often used red, yellow, black, and white. When the front has dried, paint the backs of the masks. The backs can be painted solid or with a design, or another pair of faces can be painted so that the masks are reversible.

6. Insert feathers with a bit of glue on the shaft into the individual cells in the corrugated sides of the finger masks. A few fatter feathers can be trimmed along the shaft to about an inch from the tip to add variety.

7. Insert two fingers in the finger holes. The feathers will stick out like spokes and will wave with the motion of hands and arms when dancing.

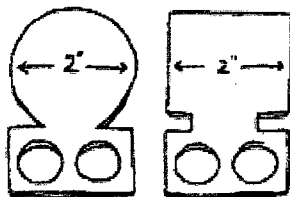

Cut shapes out of cardboard

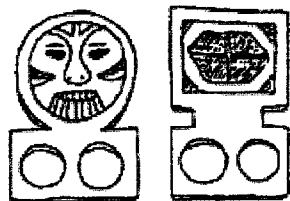

Paint faces or designs on the front and back of the cardboard shapes.

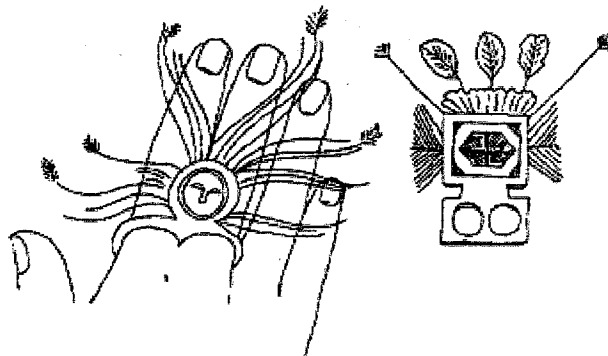

Stages

Try using tables turned on their side, refrigerator boxes cut at the top or at the bottom, with an added string and material across, to create a curtain. Make it look like a storybook or a television. Paint on scenery, glue on scenery cut from colored paper. Make different scenes on paper that you fold over as the story changes. You can make this as simple or as elaborate as you and the boys want. Remember K.I.S.M.I.F (Keep it simple, Make it fun.)

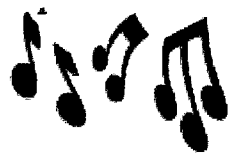
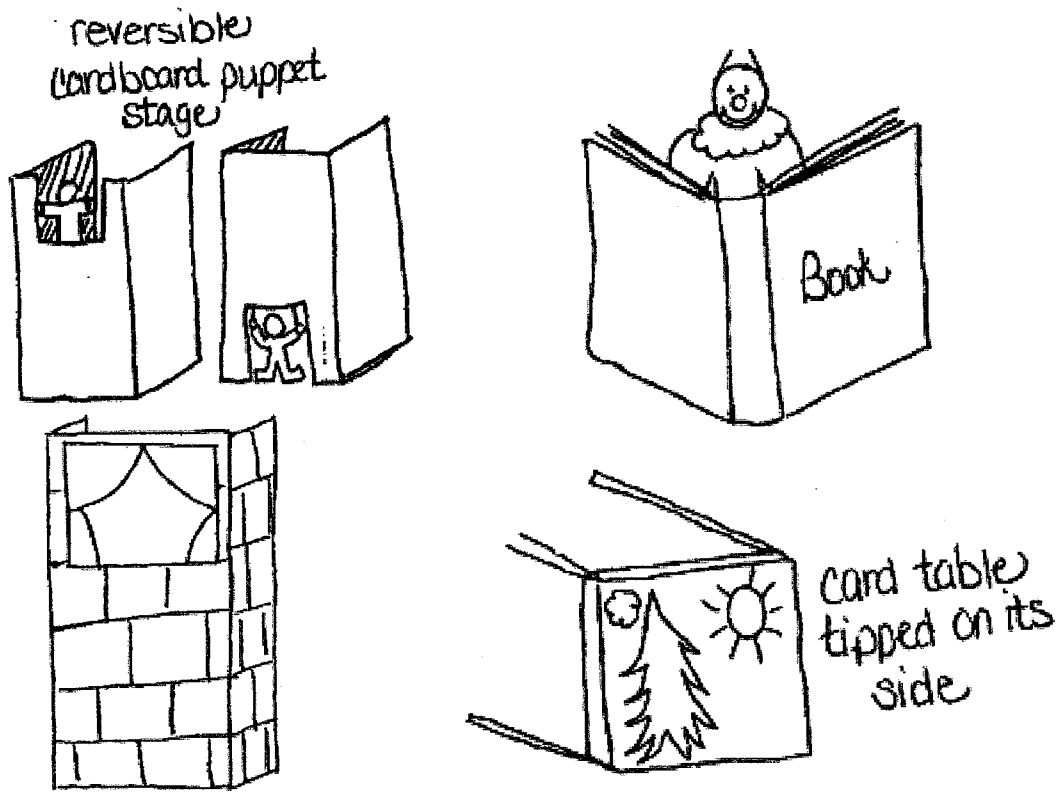

Music

Sound effects

What do boys like to do? Make CD's, download music to I pods, or MP3 players. Boys are into this and they will have a lot of fun coming up with music to go with their show. You can record sound effects or try to make your own. Once again, the boys will have a blast. You could include a song with the audience at the beginning, in the middle as an attention getter, or at the end.

Songs

Make use of boys who can play musical instruments or make home-made instruments. Every Pack monthly theme will fit the Music requirement. Have the boys sing and have fun!